

REVISIONS				
ZONE	REV	DESCRIPTION	DATE	APPROVED
	A	ECN 0657	28-JUL-08	
	B	ECN 0784	06-JUN-16	
	C	ECN 0797	17-FEB-17	
	D	ECN 0853	25-NOV-24	

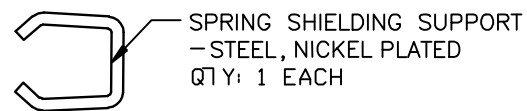
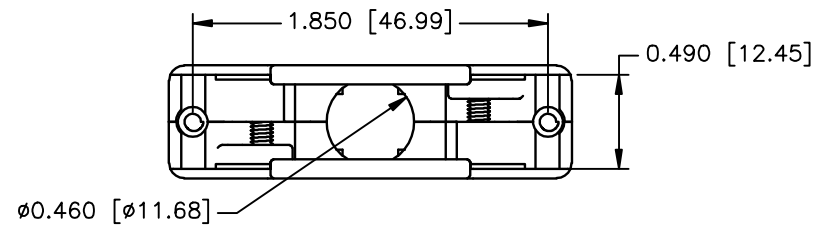
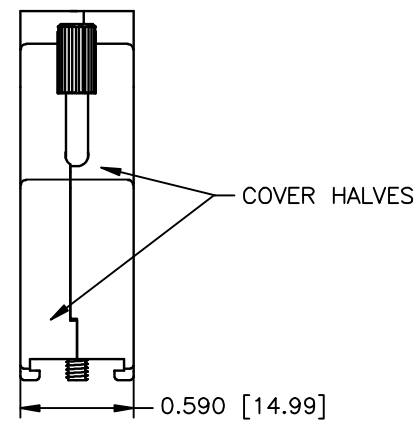
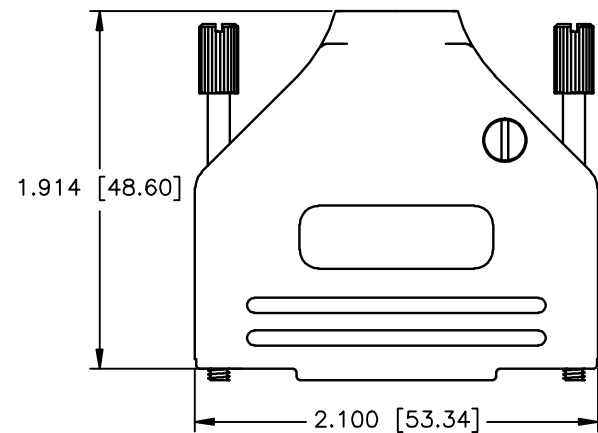

PART NUMBER INFORMATION

PART#	THUMBSCREW OPTION	SUPPLIED
MHDETZK25BKK	MATERIAL - STEEL FINISH - BLACK	PACKAGED
MHDETZK25BPCK	MATERIAL - STEEL FINISH - CLEAR ZINC CAP - PLASTIC - BLACK	PACKAGED

CONNECTOR COVER:  
 1.MATERIAL: ZINC DIE-CAST  
 2.FINISH: BLACK POLYESTER RESIN  
 3.DIMENSIONS: INCHES [MM]  
 4.TOLERANCE: ±0.015 [0.381]

COMPRESSION INSERT TREE  
 1.MATERIAL: ABS  
 2.COLOR: BLACK  
 3.DUROMETER: 70 - TYPE D  
 4.DIMENSIONS: INCHES [MM]  
 5.TOLERANCE: ±0.015 [0.381]

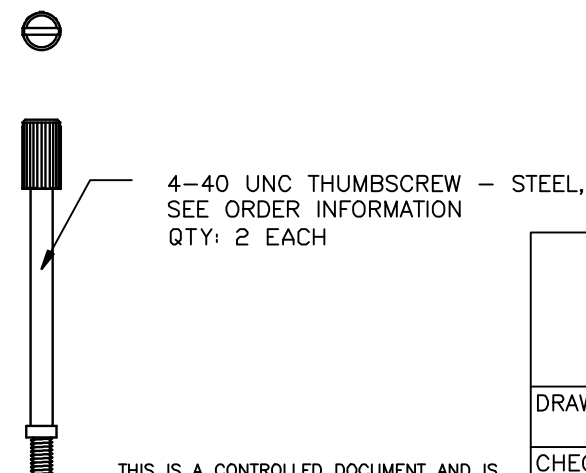
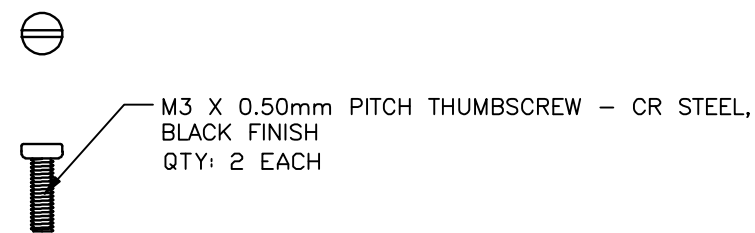
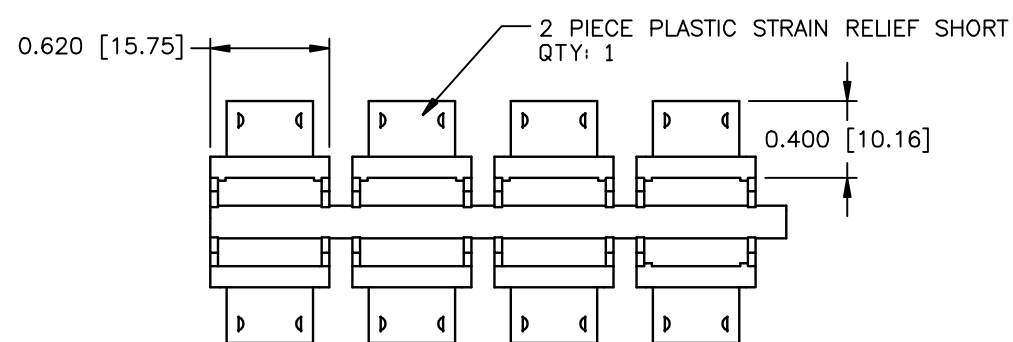

THIS IS A CONTROLLED DOCUMENT AND IS SUBJECT TO CHANGE. CONTACT NORTHERN TECHNOLOGIES ENGINEERING FOR THE LATEST REVISION.

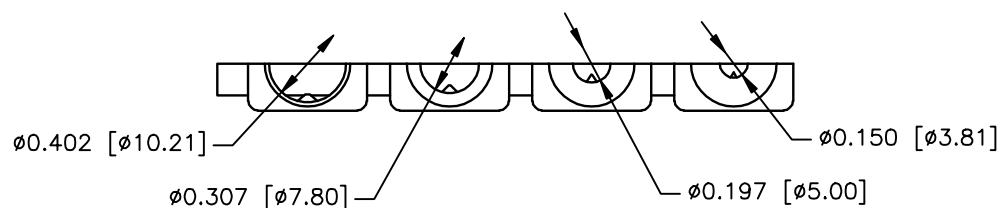

UNLESS OTHERWISE SPECIFIED		Northern Technologies		
1. ALL DIMENSIONS ARE IN INCHES (MM) 2. DIMENSIONS ARE TYPICAL		THIS DRAWING IS THE PROPERTY OF NORTHERN TECHNOLOGIES AND SHOULD NOT BE REPRODUCED WITHOUT NORTHERN TECHNOLOGIES WRITTEN PERMISSION.		
DRAWN JSD 25-JUL-06		PART NUMBER SEE PART NUMBER INFORMATION		
CHECKED SCN 25-JUL-06		DESCRIPTION CMA 25 STRAIGHT EXIT METAL COVER BLACK		
ISSUED 25-JUL-06		SIZE B	CODE 200_184	REV
		SCALE N.T.S.	DWG NO. 0002-200-184	
		SHEET 1 OF 1		